

 newbits

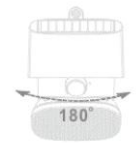

Moving
Horizontally

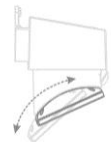

Vertical
Sliding

MARS 2

LAMPĂ SOLARĂ DE PERETE

INTRODUCERE

Specificațiile produsului

01 INTRODUCERE

02 CATALOG

03 AVANTAJE PRINCIPALE

04 ALTE AVANTAJE

05 SPECIFICAȚII

06 DIAGRAMA OPTICA

07 DIMENSIUNI

08 MAI MULTE DETALII

09 TEHNOLOGIE NUCLEU

10 DETALII PACHET

11 UTILIZARE



2000LUMENI SUPER LUMINOS
LAMPAR SOLAR DE URGENȚĂ

Distribuție științifică a luminii





Glisare verticală

Avantajele produsului

Cap de fixare reglabil în 4 direcții (sus/jos/dreapta/stânga)
pentru o zonă de iluminare mai mare

Uimitor ca un CUB MAGIC.



Deplasarea orizontală



Articol: SWL-12	Putere :20W
Panou solar	
Putere	Epoxid monocristalin, 1W
baterie Li-ion	
Capacitate	3.7V 14.8WH 2AH/PC
Temp. de încărcare/descărcare	0~45°C/-20~60°C
Timp de incarcare	20H
LED (OSRAM)	2835 39 buc;
Temp. culoare	4000K Ra 80+
Eficienta	190lm/W
LED UV	-
Performanta	
Timp de iluminare în zilele ploioase	>10 zile
Modul de control	Buton comutator, ON/OFF Apăsare lungă 1,5 secunde
Modul de iluminare	M150+PIR 2000 lm / M20+PIR 2000 lm /M3:50lm Până în zori -
Indicarea modului	M1: Intermitent o dată, M2: Intermitent de două ori; M3: Intermitent de trei ori
Indicație de capacitate	-
PIR	120 ° > 5m
Tehnologia de baza	ALS 2.3 / TCS 1.0
Autocurățare panouri solare	-
Clasa IP/ IK	IP65 / IK10
Înălțime de instalare	3m

Diagrama simulată a drumului

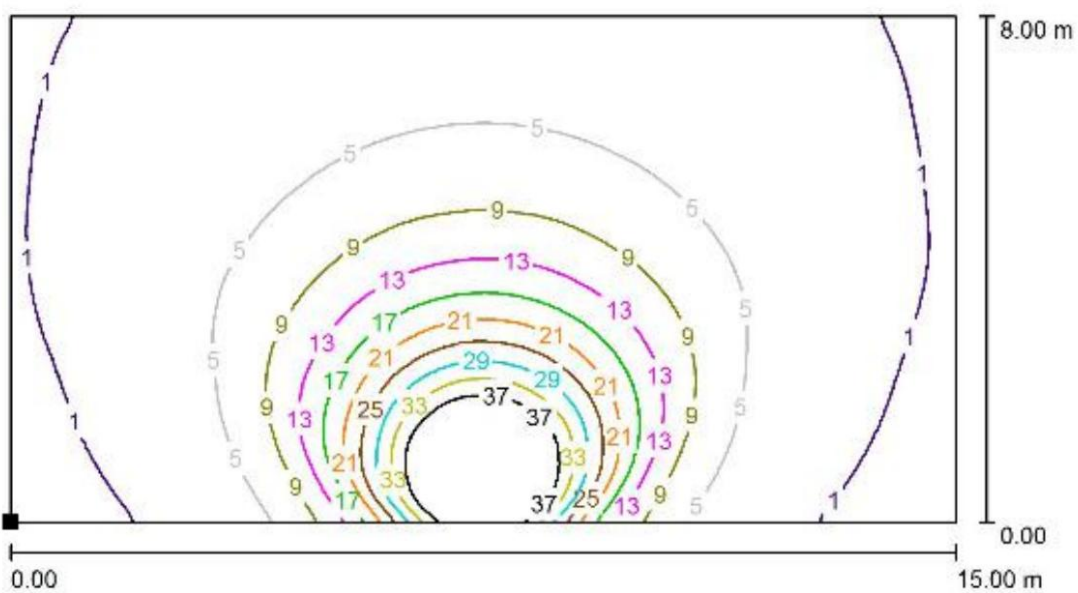

Curba de iluminare

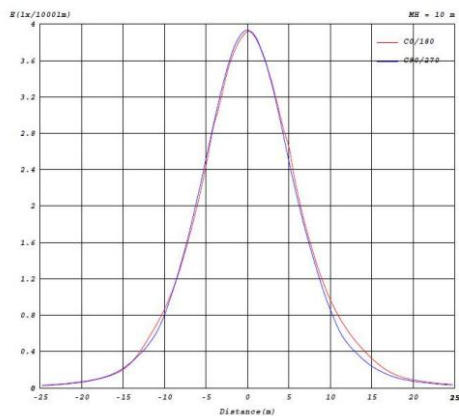

Distribuția Luminanței

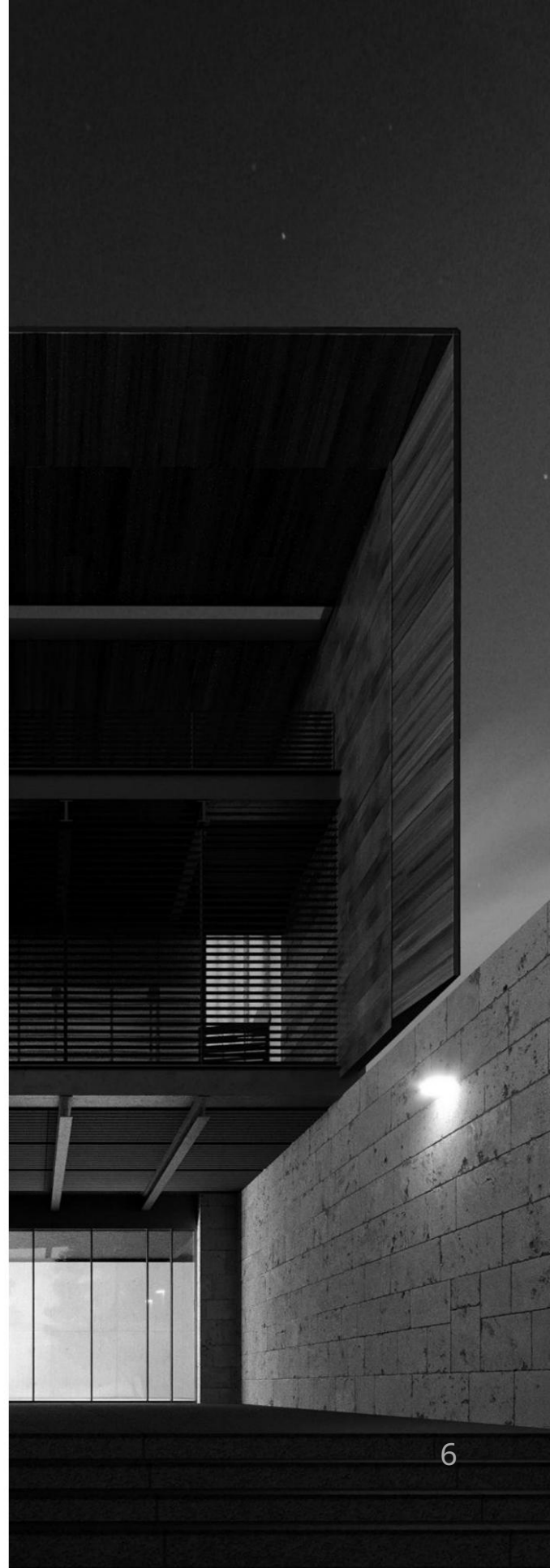
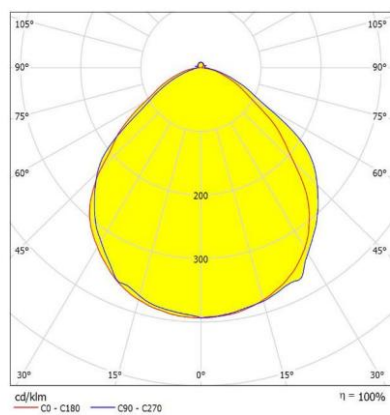

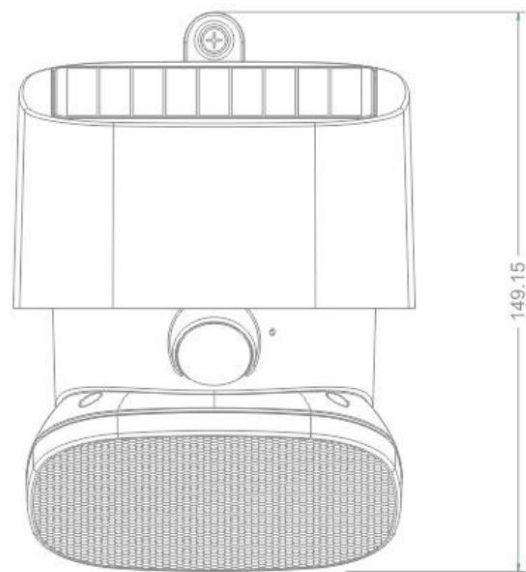
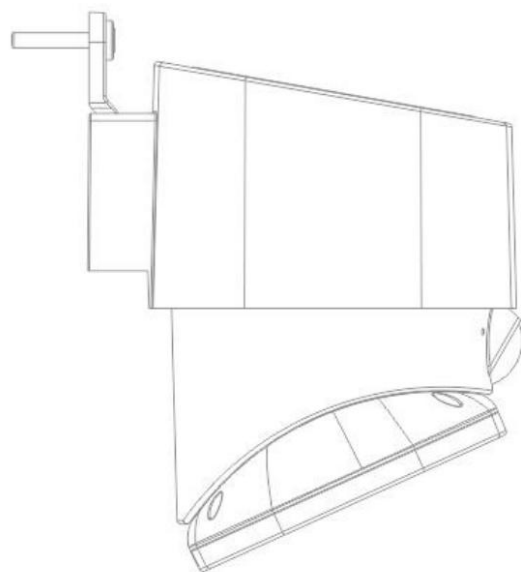
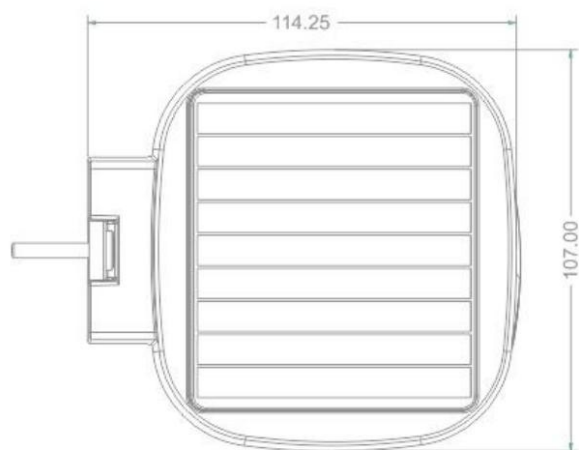

Avantaj in fiecare detaliu

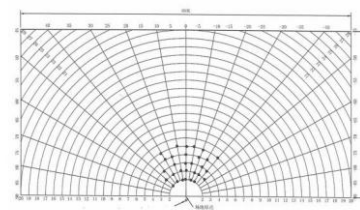

Monocristalin
Eficiență de încărcare solară: > 21%

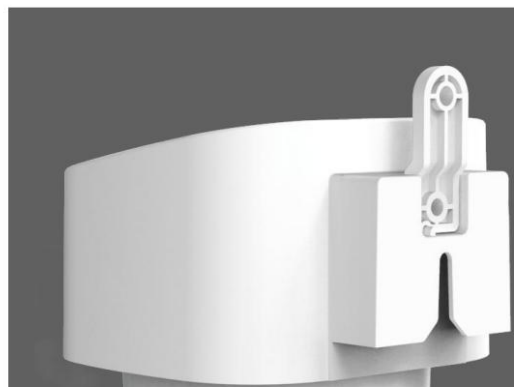

Ușor de instalat



Senzor PIR de înaltă sensibilitate
Comutatoare



Glisare verticală

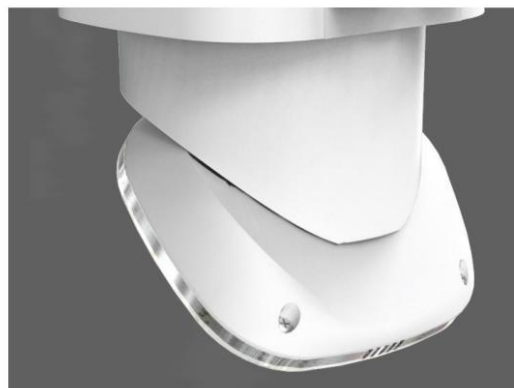

Detalii din spate

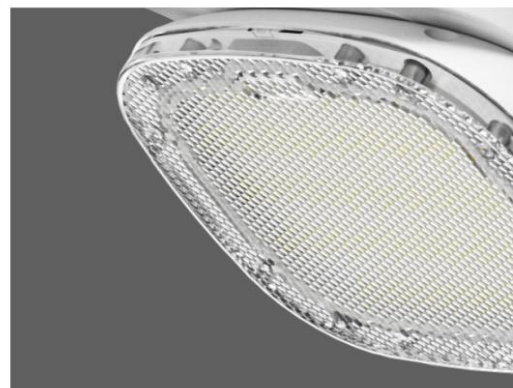

LED-uri cu lumen mare
190lm/W



O companie mare ar trebui să acorde întotdeauna cea mai mare atenție designului fiecărui detaliu și spiritul de măiestrie ar trebui să fie completat în întregul proces de proiectare și producție în masă.

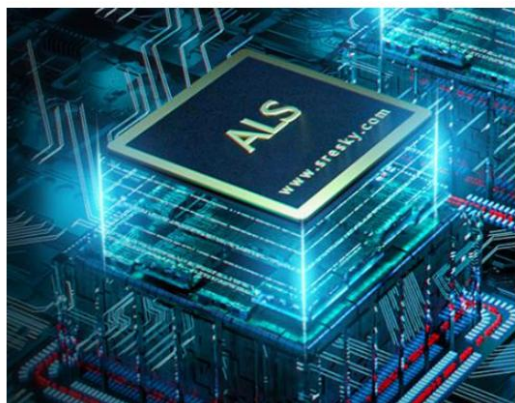

AVANTAJUL ALS

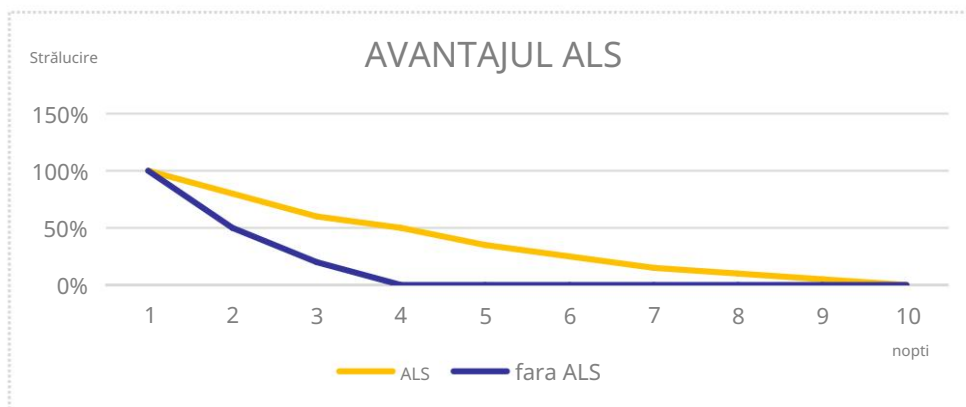

AVANTAJUL TCS

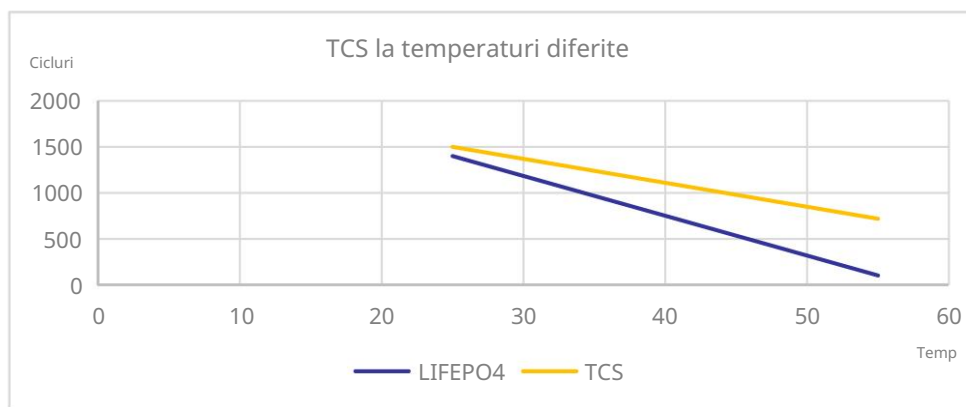

LISTA DE PRODUSE

Șurub: 3 buc
 Șuruburi cu expansiune: 2 buc
 ACCESORII: 1BUC
 PIN: 1 buc

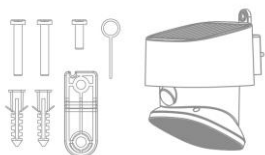

LISTA DE PRODUSE

CUTIE INTERIOARĂ
 DIMENSIUNE: 113*125*140mm
 1BUC/1 CUTIE



CUTIE COLOR

2 STRATURI
 1 STRAT = 12 CUTII

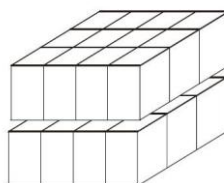

MASTER CARTON
 DIMENSIUNE: 467*387*298mm
 24BUC/CTN

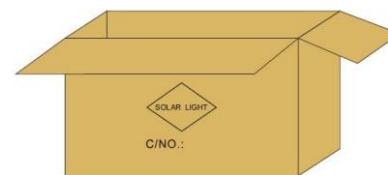

NUMĂRUL STRATULUI

CUTIE DE CARTON

PASUL 1

PASUL 2

PASUL 3

PASUL 4

NUMARUL MODELULUI	METODĂ AMBALARE	PCS/CTN	CANTITATE (BUC)	CTN CANTITATE	DIMENSIUNE CARTON (MM)	NW (KG)	GW (KG)
SWL-12	CUTIE COLOR	1	1	1	113*125*140	0,5	0,55
	CUTIE DE CARTON	24	24	1	467*387*298	12	12,5

Greutatea netă și greutatea brută sunt doar pentru referință

S / O / L / A / R / L / I / G / H / T

VA MULTUMIM!

CONTACT: Email: info@newbits.ro